

FAIRCHILD MODEL 4100A PNEUMATIC PRECISION REGULATOR

Installation, Operation and Maintenance Instructions

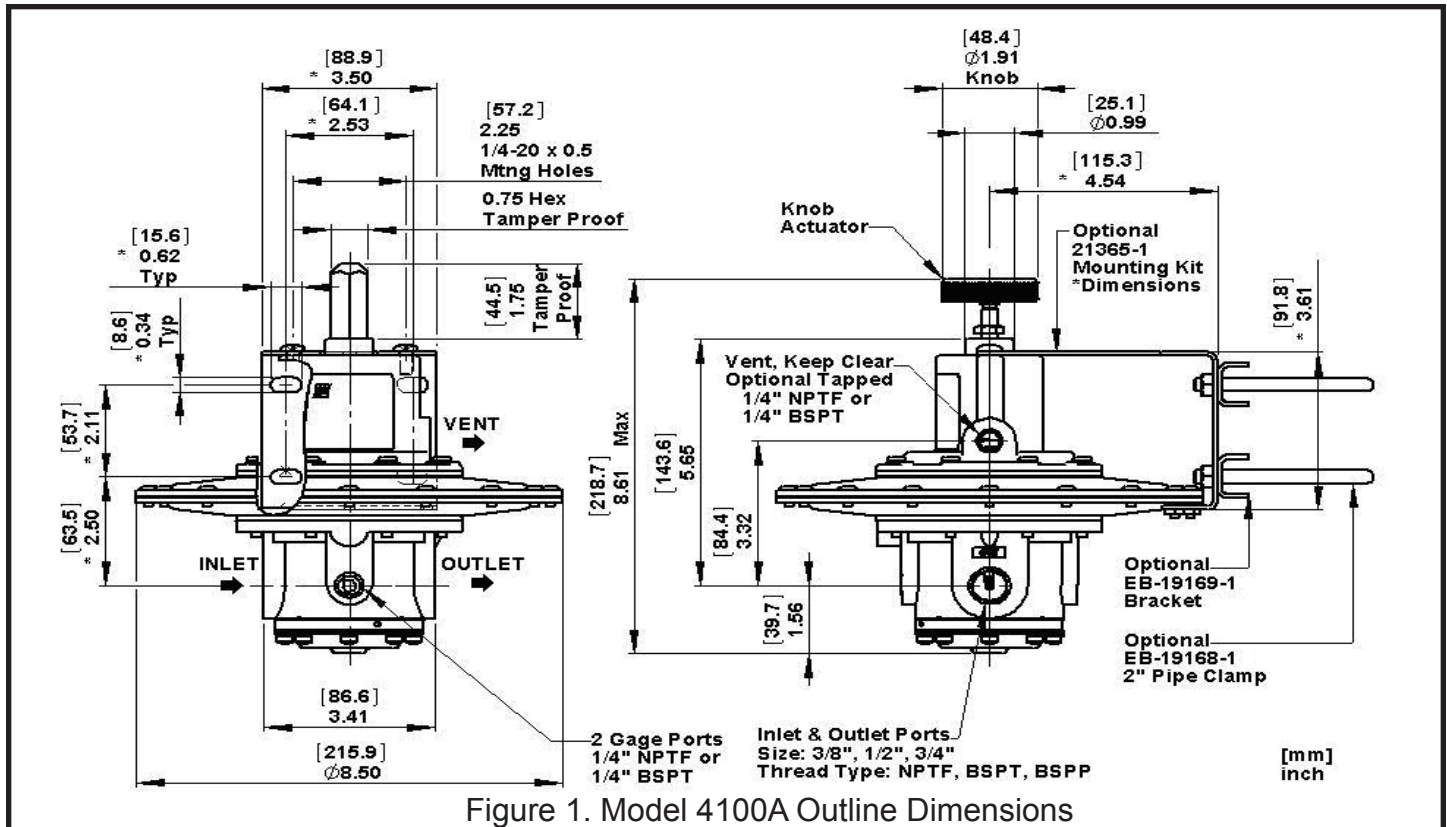

INSTALLATION

Use the two 1/4-20 tapped holes in the Bonnet to panel mount the Model 4100A. The unit can also be mounted using optional 21365-1 mounting bracket. You can mount the regulator in any position without affecting its operation.

Clean all pipelines to remove dirt and scale before installation.

Apply a minimum amount of pipe compound to the male threads of the fitting only. **Do Not use Teflon tape as a sealant.** Start with the third thread back and work away from the end of the fitting to avoid contaminating the regulator. Install the regulator in the air line.

The Inlet and Outlet ports are labeled "In" and "Out". Tighten all connections securely. Avoid undersized fittings that will limit the flow through the regulator. For more information, see Figure 1.

NOTES: Oil free air must be applied to the regulator. Use a filter to remove dirt and entrained liquid in the air line ahead of the regulator. If an air line lubricator is used, it **MUST** be located downstream of the regulator to avoid interference with performance.

OPERATION

The Model 4100A is a high-flow, low pressure, non-bleeding regulator that precisely controls a set pressure.

Before you place the regulator into service for the first time, turn the Regulator Knob counterclockwise to relieve the tension on the Range Spring. To operate the regulator, slowly turn the knob in a clockwise direction until it reaches the required set pressure. For more information, see Figure 1.

Maintenance

To clean the Model 4100A, use the following steps:

1. Shut off system pressure to the regulator to prevent air from escaping. It is not necessary to remove the regulator from the air line.
2. Remove the four Screws and Washers (between ports) from the bottom of the unit. For more information, see Figure 2.
3. Remove the Inner Valve Assembly. For more information, see Figure 2.
4. Wash the Inner Valve Assembly with a solvent. Exercise care to prevent damage to diaphragms and valve facings. Avoid solvents such as acetone, carbon tetrachloride and trichlorethylene.
5. Replace the assembly carefully. Ensure that the Vent in the exterior part of the Inner Valve Assembly and the Exhaust Vent in the Bonnet are clear. For more information, see Figure 2.

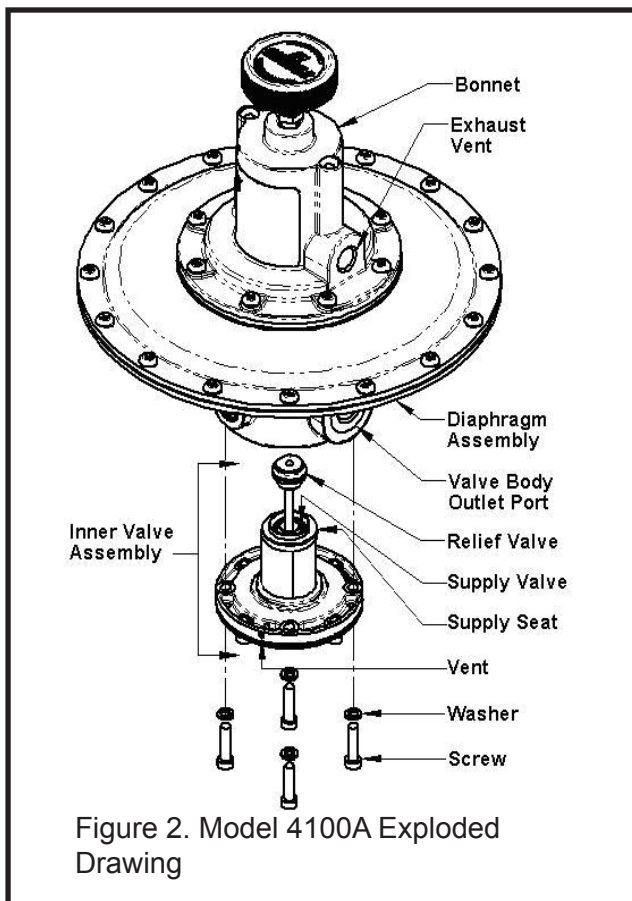

Troubleshooting

Problem	Source	Solution
External Leakage	<ul style="list-style-type: none"> •Bonnet Screws •Diaphragm 	<ul style="list-style-type: none"> •Tighten Bonnet Screws •Tight Diaphragm Screws
Leakage From Exhaust Vent	<ul style="list-style-type: none"> •Relief Valve •Supply Valve •Supply Seat 	<ul style="list-style-type: none"> •If contaminated clean the source/ Body. If damaged install service kit.

Legal Notice

The information set forth in the foregoing Installation, Operation and Maintenance Instructions shall not be modified or amended in any respect without prior written consent of Fairchild Industrial Products Company. In addition, the information set forth herein shall be furnished with each product sold incorporating Fairchild's unit as a component thereof.

Service Kit

Part Number	Use With
21364-N	All Ranges, Nitrile Elastomers
21364-J	All Ranges, Viton Elastomers

