

# FAIRCHILD T6000 Electro-Pneumatic Transducers

## Standard and Extended Ranges

### Installation Instructions

#### GENERAL INFORMATION

The Model T6000 can be mounted directly onto a flat surface using two 10-32 screws.

The Model T6000 is supplied with a Mounting Kit 16799-1 for Panel or Wall Mounting. For detailed information, see page 2.

**Figure 1. TA6000 Outline Dimensions**

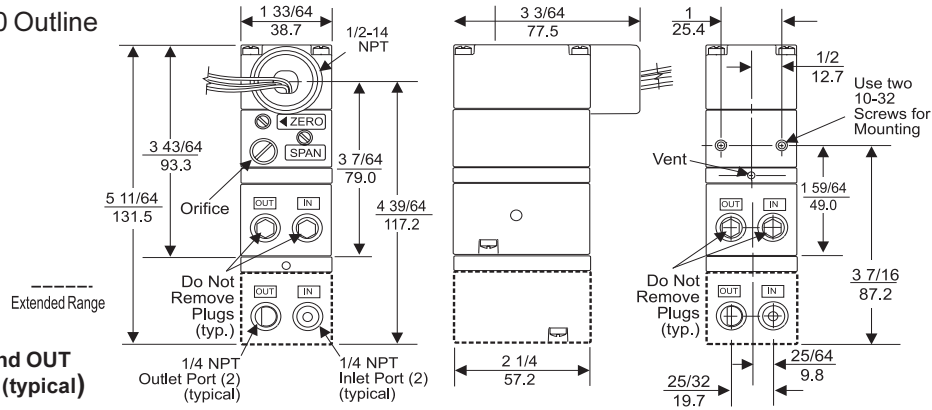

**Note: Unused IN and OUT Ports are plugged (typical)**

**Figure 2. TT6000 Outline Dimensions**

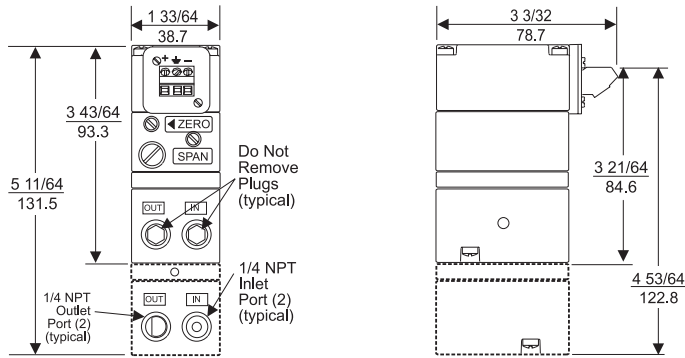

**Figure 3. TD6000 Outline Dimensions**

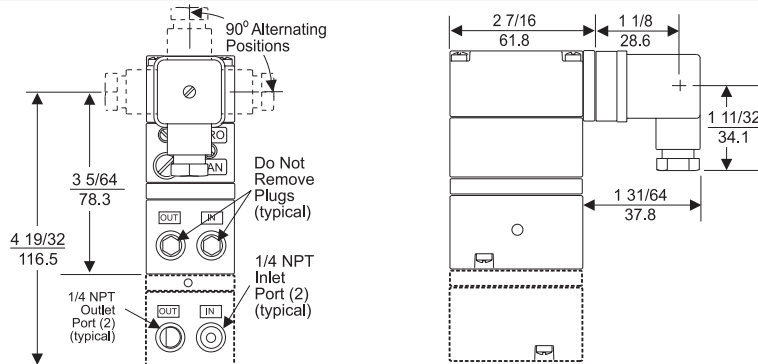

**Figure 4. TR6000 Outline Dimensions**

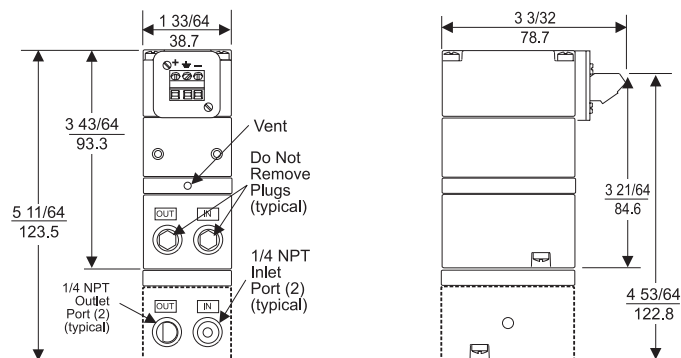

**Installation**

The Model T6000 is supplied with a DIN Rail Mounting Kit 16893. For detailed information, see Figure 6. A Mounting Kit 19254-1 is available when installing the unit on a 2" pipe, see Figure 7.

**NOTE: The TR6000 Transducer is designed for use with the TR Rack Kit. Physically, it is the same as the TT6000 (Terminal Block) Unit except that the terminal block has been rotated to the rear. For detailed information, see Figure 4. "TR6000 Outline Dimensions" on page 1.**

**Figure 5. Mounting Kit 16799-1 (Included with Unit)**

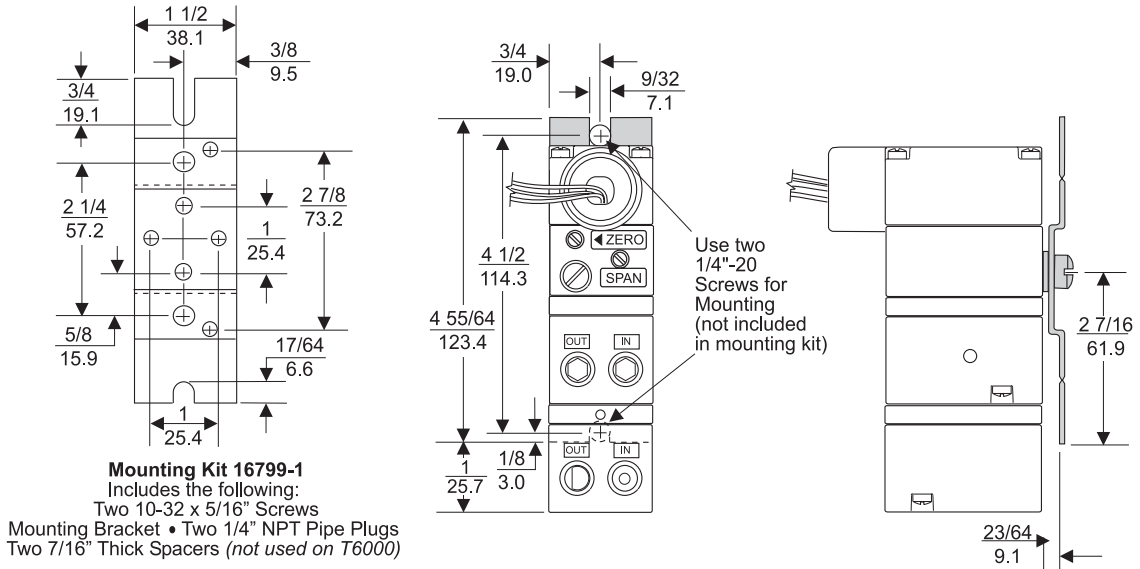

**Figure 6. DIN Rail Mounting Kit 16893 (Included with Unit)**

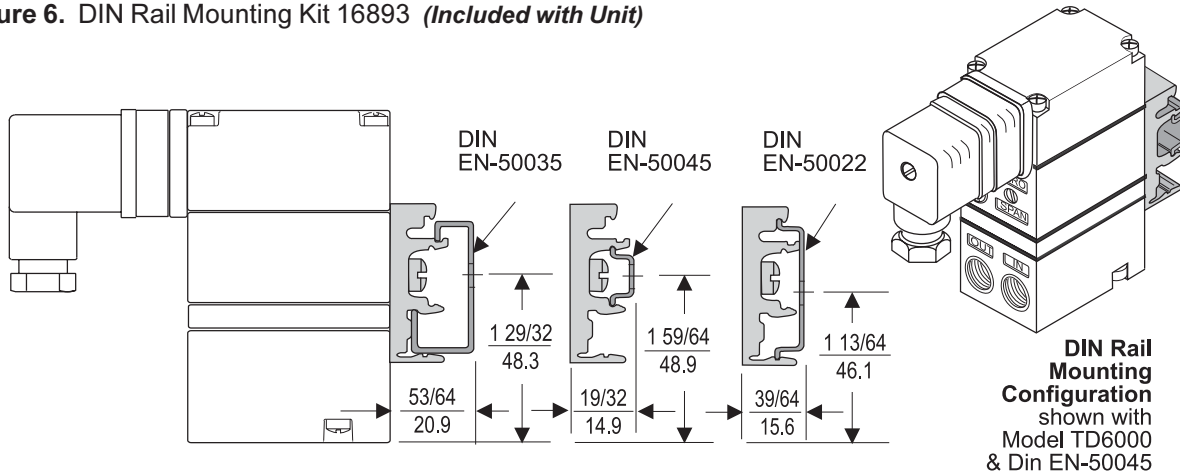

**Figure 7. Mounting Kit 19254-1 (Sold Separately)**

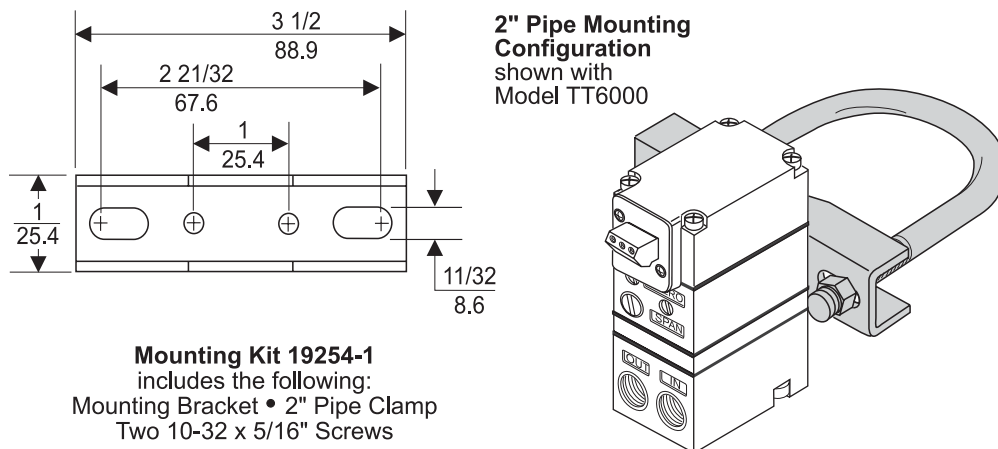

## Pneumatic Connection

Clean all pipelines to remove dirt and scale before installation. Apply a minimum amount of pipe compound to the male threads of the fitting only. **Do Not use teflon tape as a sealant.** Start with the third thread back and work away from the end of the fitting to avoid contaminating the transducer. Install the transducer in the air line. The inlet and outlet ports are labeled on the ends of the transducer. Tighten connections securely. Avoid undersized fittings that will limit the flow through the transducer and cause pressure drop down stream.

**NOTE: Oil free air is required. Use a filter to remove dirt and liquid in the air line ahead of the transducer. If an air line lubricator is used, it MUST be located downstream to avoid interference with transducer performance.**

**The user is responsible for insuring that the environment in which the unit will be installed and the operating gas are compatible with the materials in the transducer.**

## Electric Connection

Make connections as shown in Figure 8.

**CAUTION:** Effective November 1997 (DATE CODE NE), the DIN Connector terminal connections have been changed. The ground connection has been moved from terminal #3 to the (⊕) terminal. When replacing an existing unit, correct wiring on the mating connector.

## Wiring in Hazardous Areas

Table 1. Hazardous Location Wiring Practices.		
Country	Agency	Code
U.S.	FM	ANSI/ISARP 12.6 & ANSI/NFPA 70
Canada	CSA	CEC Part 1
Europe	ATEX	EN 50 039, EN 60079-14, IEC 60079-14

## Intrinsically Safe Connections

Table 2. Intrinsically Safe Installation Drawings.	
Underwriting Group	Drawing Number
FM (Factory Mutual)	EC-16984
CSA (Canadian Standards)	EC-18005
ATEX	EC-18007

## Limitations/Exceptions

Type 3R - TAF, TDF upright position
TFA-CLI, Div 2 wiring per NEC/ANSI/NFPA 70 for installation without wiring parameters. TDF, TTF, TRF require an enclosure.
For dry locations and voltages less than 60Vdc, TTF & TRF units must be in an enclosure.
Where loop voltages exceed 60Vdc (dry locations) or 30Vdc (potentially damp locations), the TTF and TRF versions must be installed meeting the electrical shock and fire protection requirements of ANSI/ISA S82.01.

## MAINTENANCE

**To clean the Orifice, use the following procedure:**

1. Shut off the valve that is supplying air to transducer. **It is not necessary to remove the Transducer from the air line.**
2. Remove the Orifice Assembly from the unit. For detailed information see Figure 1 "T6000 Calibration Configuration on page 1.
3. Clean with alcohol and dry with compressed air.

## NOTES:

**Parts must be completely dry before reassembling.**

**If the standard maintenance procedure does not correct the trouble, install the appropriate Service Kit below:**

- 16798-1 (3-15, 3-27 & 6-30 psig  
Standard Range)
- 18238-1 (0-30 psig Extended Range)
- 18239-1 (0-60 psig Extended Range)
- 18240-1 (0-120 psig Extended Range)
- 18039-1 (Explosion-Proof Base)

**Service Kits also include Gasket, O-Rings, and Membranes to replace "W" Option product.**

## TROUBLE-SHOOTING

Table 1. Trouble-Shooting.	
Problem	Solution (check)
No Output	Supply Pressure Clogged Orifice Input Signal
Leakage	Pneumatic Connections
Low or Improper Span Adjust	Zero and Span Adjust Supply Pressure Low Output Leakage
Erratic Operation	DC Signal Loose Wires or Connections Liquid in Air Supply Dirt in Magnet Gap

**WARNING: Failure of Transducer could result in output pressure increasing to supply pressure possibly causing personal injury or damage to equipment.**

## CALIBRATIONS/ADJUSTMENTS

### Equipment Required for Calibration:

- Pneumatic Supply capable of delivering up to 150 psig.
- Current Supply capable of delivering up to 60 mA.
- Pressure Gage capable of a digital readout up to 50 psig with an accuracy of .1%.
- Digital Volt Meter capable of a readout up to 60 mA with an accuracy of .02%.

### FULL RANGE OPERATION

**CAUTION: Over-ranging the Zero Screw can damage unit.**

#### Forward Acting Mode Adjustment

1. Connect the input signal to the transducer as shown in the Installation Instructions, II-50T6000X.
- Forward Acting Calibration-Zero
  2. Apply the minimum input signal and adjust the Zero screw for minimum output pressure. Turn screw clockwise to increase pressure and counterclockwise to decrease pressure.
- Forward Acting Calibration-Span
  3. Apply the maximum input signal and adjust the Span screw for maximum output pressure. Turn screw clockwise to increase pressure and counterclockwise to decrease pressure.
  4. Repeat steps 2-3 until the desired output range is obtained. For detailed information, see Figure 1 "TXPD6000 Calibration Configuration" on page 1.

#### Reverse Acting Mode Adjustment

5. Connect the input signal to the transducer as shown in the Installation Instructions, II-50T6000X.
- Reverse Acting Calibration-Zero
  6. Apply the minimum input signal and adjust the Zero screw for maximum output pressure. Turn screw clockwise to increase pressure and counterclockwise to decrease pressure.
- Reverse Acting Calibration-Span
  7. Apply the maximum input signal and adjust the Span screw for minimum output pressure. Turn screw clockwise to decrease pressure and counterclockwise to increase pressure.
  8. Repeat steps 6-7 until the desired output range is obtained. For detailed information, see Figure 1 "TXPD6000 Calibration Configuration" on page 1.

### SPLIT RANGE OPERATION

All units have the capability to be split ranged or set for any output in the range as long as the Output Span is equal to or greater than the minimum Span.

### ATEX Directive - Special Conditions for Safe Use:

The enclosure is manufactured from aluminum alloy. In rare cases, ignition sources due to impact and friction sparks could occur. This shall be considered when the equipment is installed in locations that specifically require Group II, category 1G equipment.

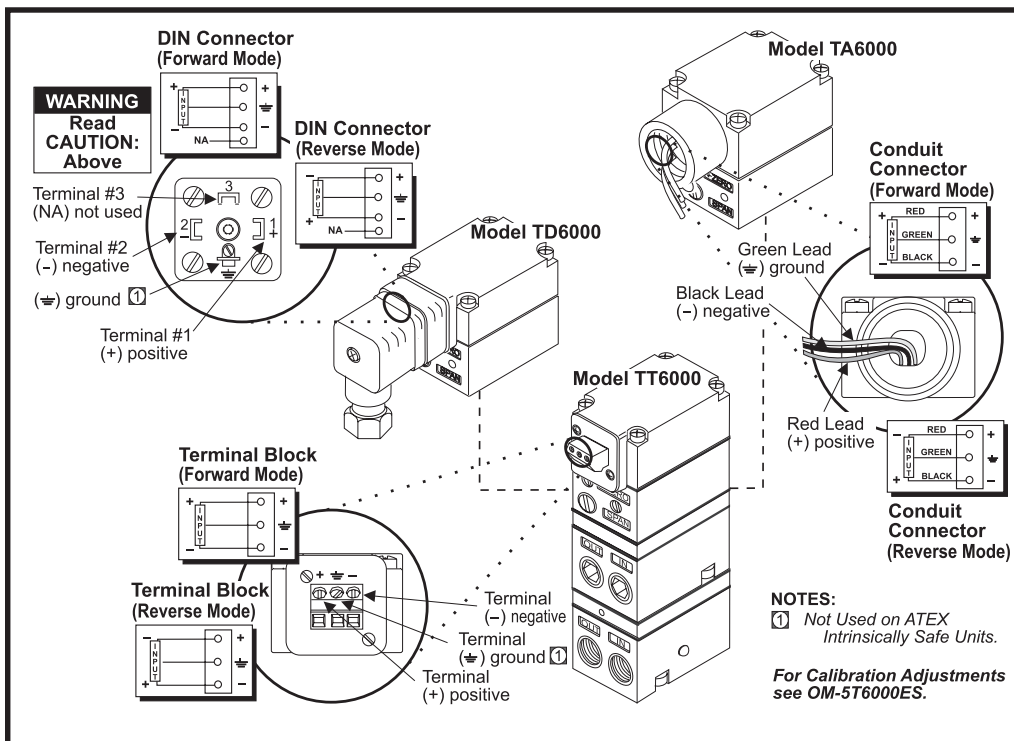

### LEGAL NOTICE:

The information set forth in the foregoing Operation and Maintenance Instructions shall not be modified or amended in any respect without prior written consent of Fairchild Industrial Products Company. In addition, the information set forth herein shall be furnished with each product sold incorporating Fairchild's unit as a component thereof.



ISO 9001:2000  
Certified